

Public  
Dr. Uday Nabar  
15-10-2011

# *Organic Pigments & Intermediates Industry in India*

Presentation at: India-Chem Gujarat 2011, Gandhinagar, Gujarat

By  
Dr. Uday Nabar  
Consultant, Clariant Chemicals (India) Ltd





Exactly your chemistry.



# Contents

- ❑ Pigments : A Historical Perspective.
- ❑ World Organic Pigments Industry & Market.
- ❑ Indian Organic Pigment Industry & Market.
- ❑ Pigments : Engineering & Technology.
- ❑ Pigments : Research & Development.
- ❑ Pigment Intermediates Industry
- ❑ Product Safety
- ❑ Summary & Outlook.

# *Pigments: A Historical Perspective*

- Colour is an **exciting & integral** part of our every-day life ! 
- **Mother nature** was first to use colours in abundance & in variety of ways.
- Probably learning from nature, 20,000 years ago prehistoric man created **paintings in caves** in France & Spain. 
- And afterwards **in 3000 BC**, ancient Egyptians created paintings using Cinnabar, Accurite & Lapis Lazuli. 
- The time moves on .....& with it **new inventions** are made !
- One such invention is a synthetic colourant '**Mauvine**' by **William Perkin** ca **150 years ago** which led to industrial manufacture of pigments & dyes.











# World Pigment Manufacturing: Demographics

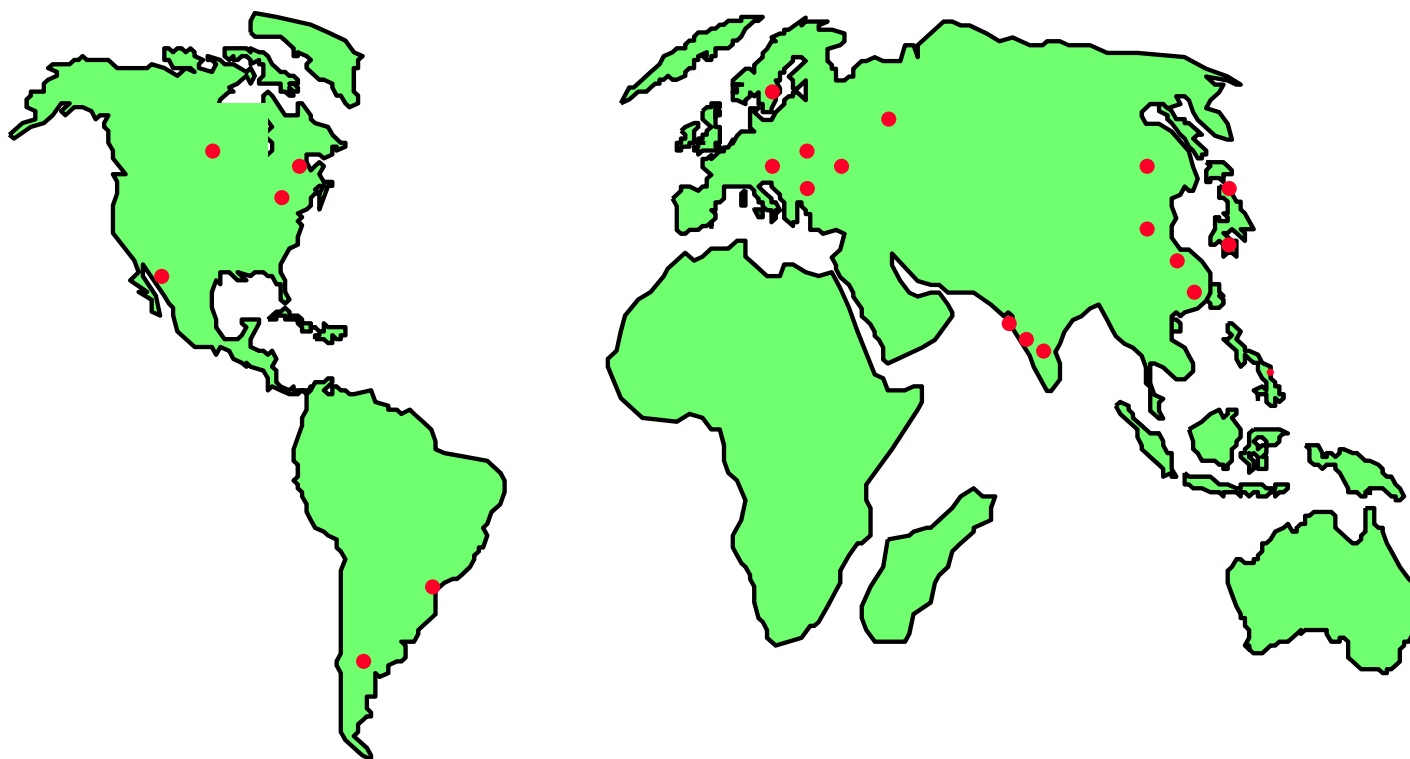

- What constitutes the organic pigment market ?
- Where are organic pigments produced ?
- Who are the major players ?

# World Pigment Manufacturing: Demographics

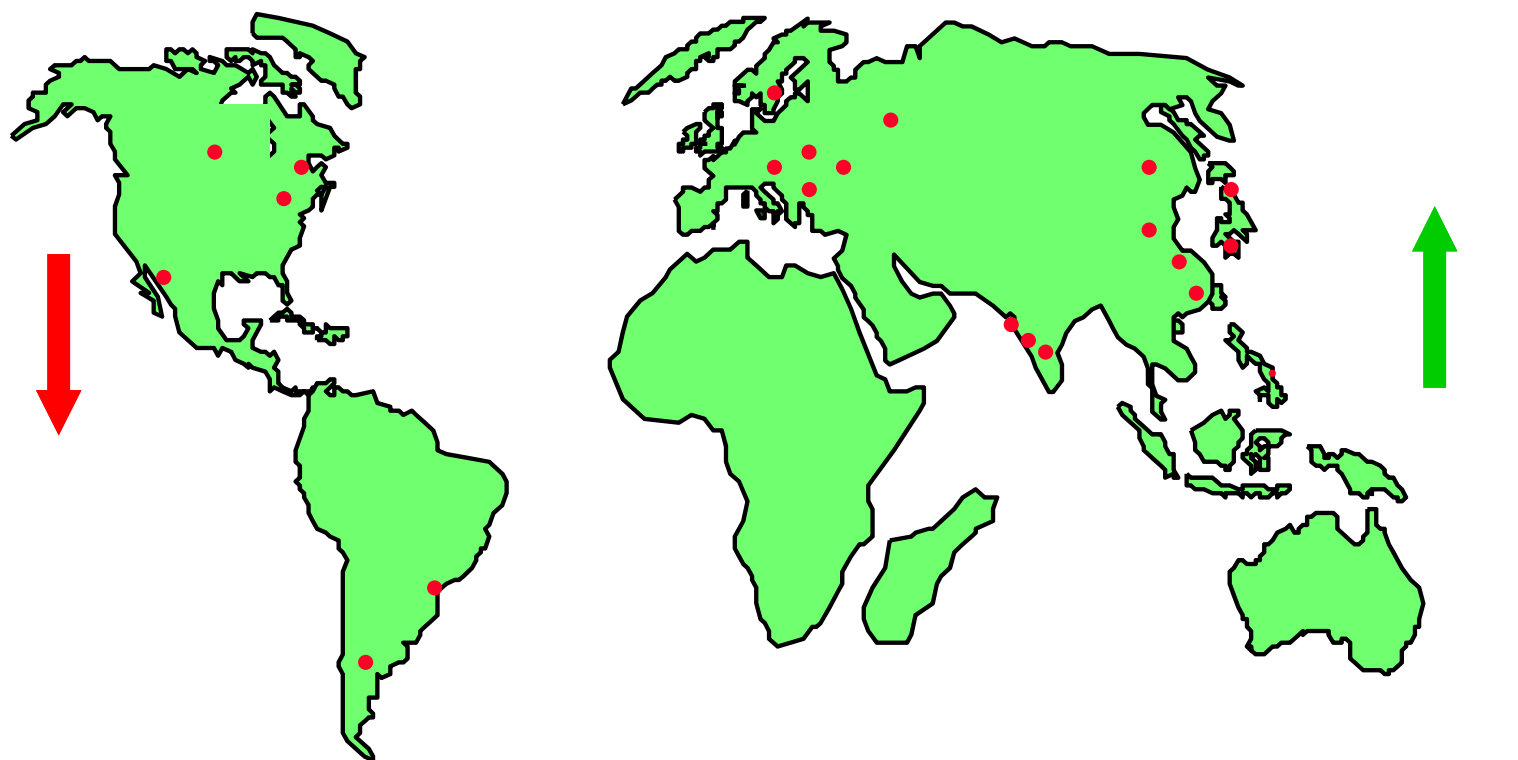

1993 Trend 2010

Somewhere plants closed & elsewhere started !

# World Organic Pigment Production Over the Years



Exactly your chemistry.

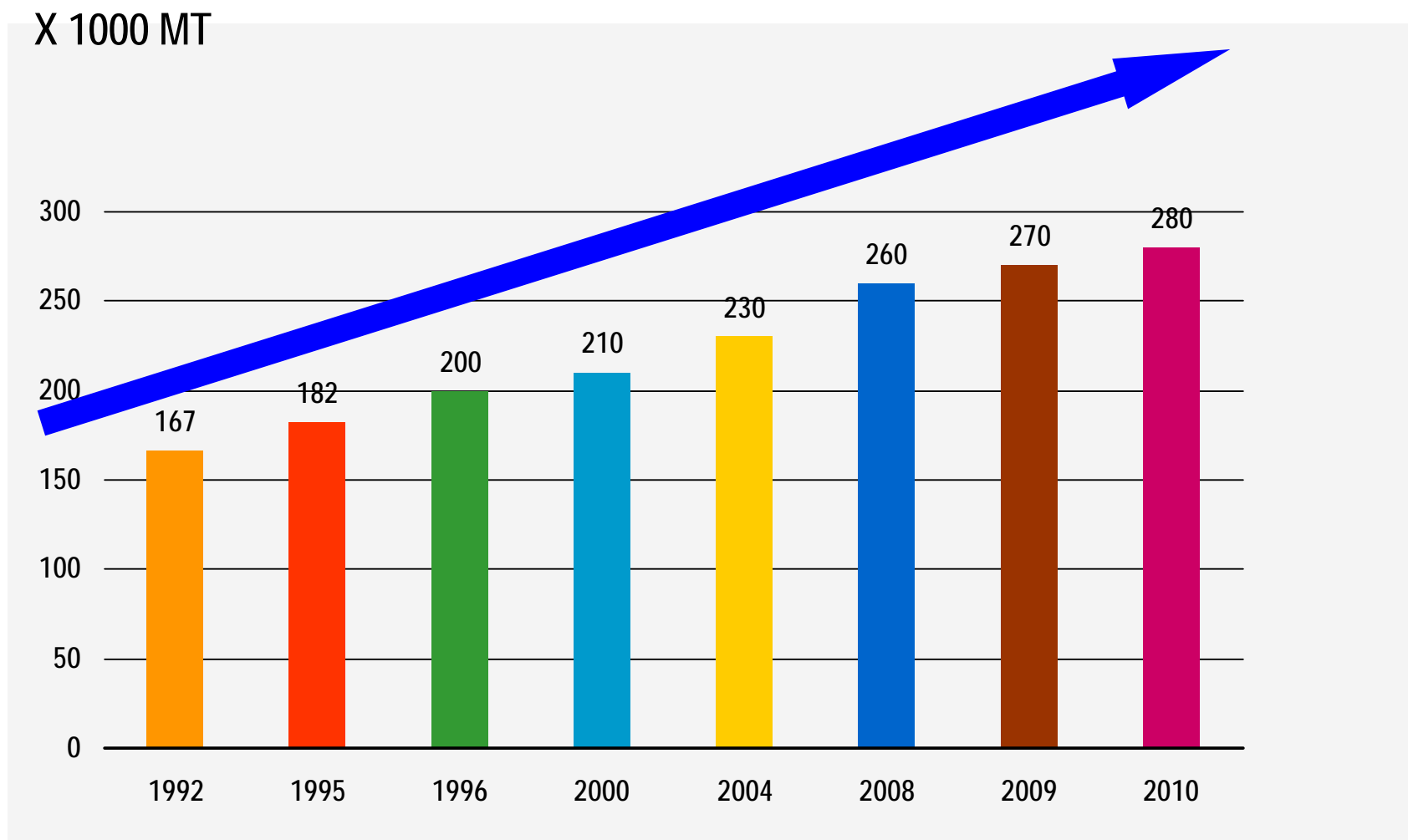

In recent years the growth is about 3 % only

# World Market for Pigments : By Region

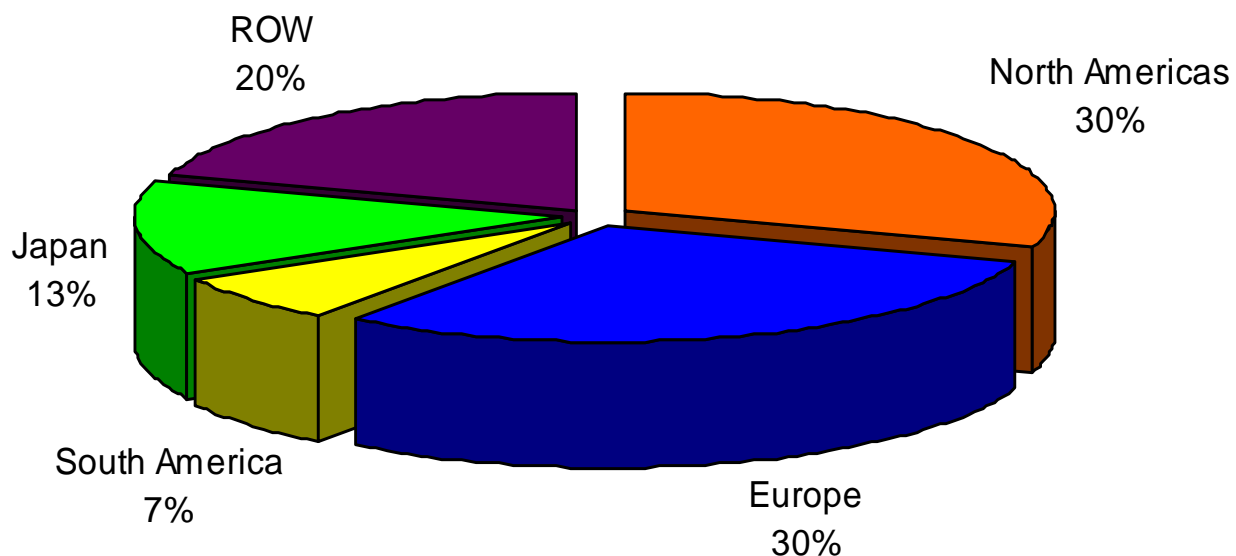

Europe & North Americas together have ca. 60% of world market.

Valuewise organic pigments [ 280,000 MT] global market is US \$ 5 bio.

For Comparison:

Inorganic Pigments : 6.5 mio MT (US\$ 5.4 bio)

Organic Dyes: 1.4 mio MT (US\$ 7 bio)

# World Market for Pigments: End Use Application

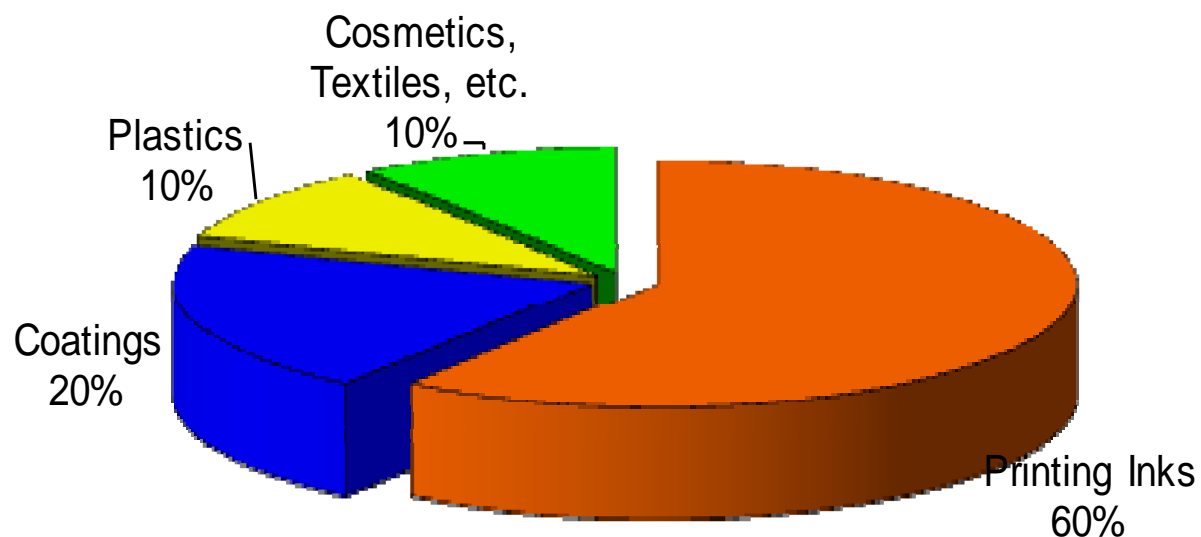

Printing Inks & Coatings together have ca 80% market share.

# World Market for Pigments: Pigment Type

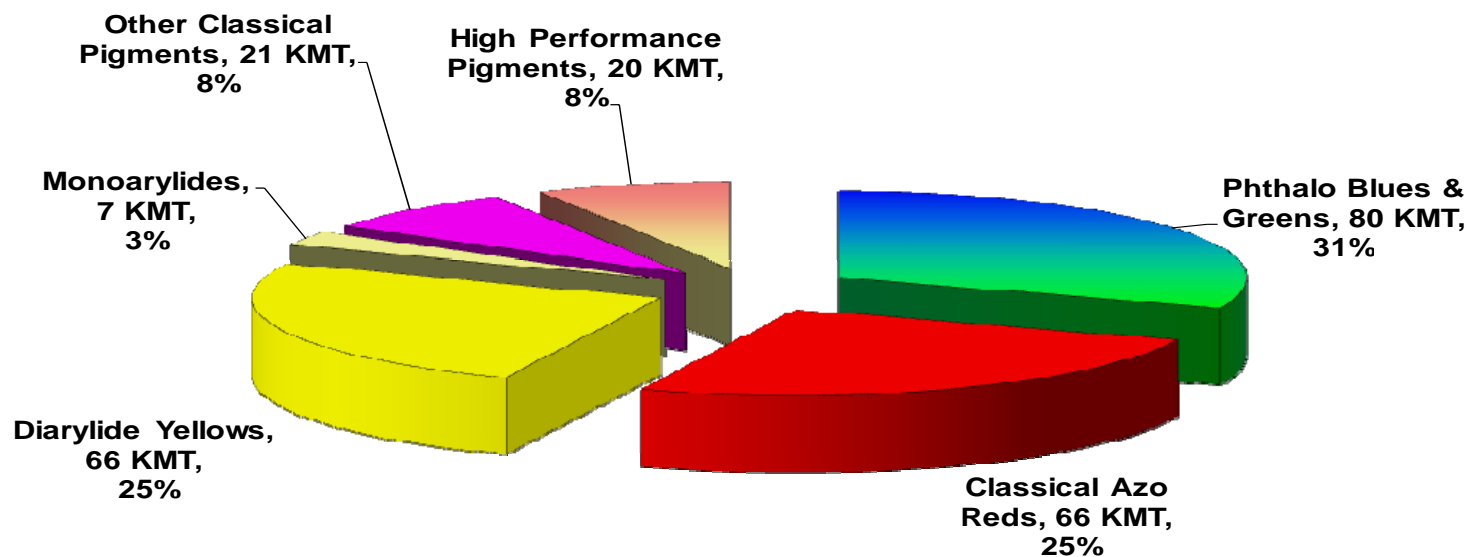

- World Production: ca. 280,000 MT
- High Performance Pigments share is up to 8 % ; but it is continuously growing.

# Two Important States for Pigment Manufacturing in India - Gujarat & Maharashtra

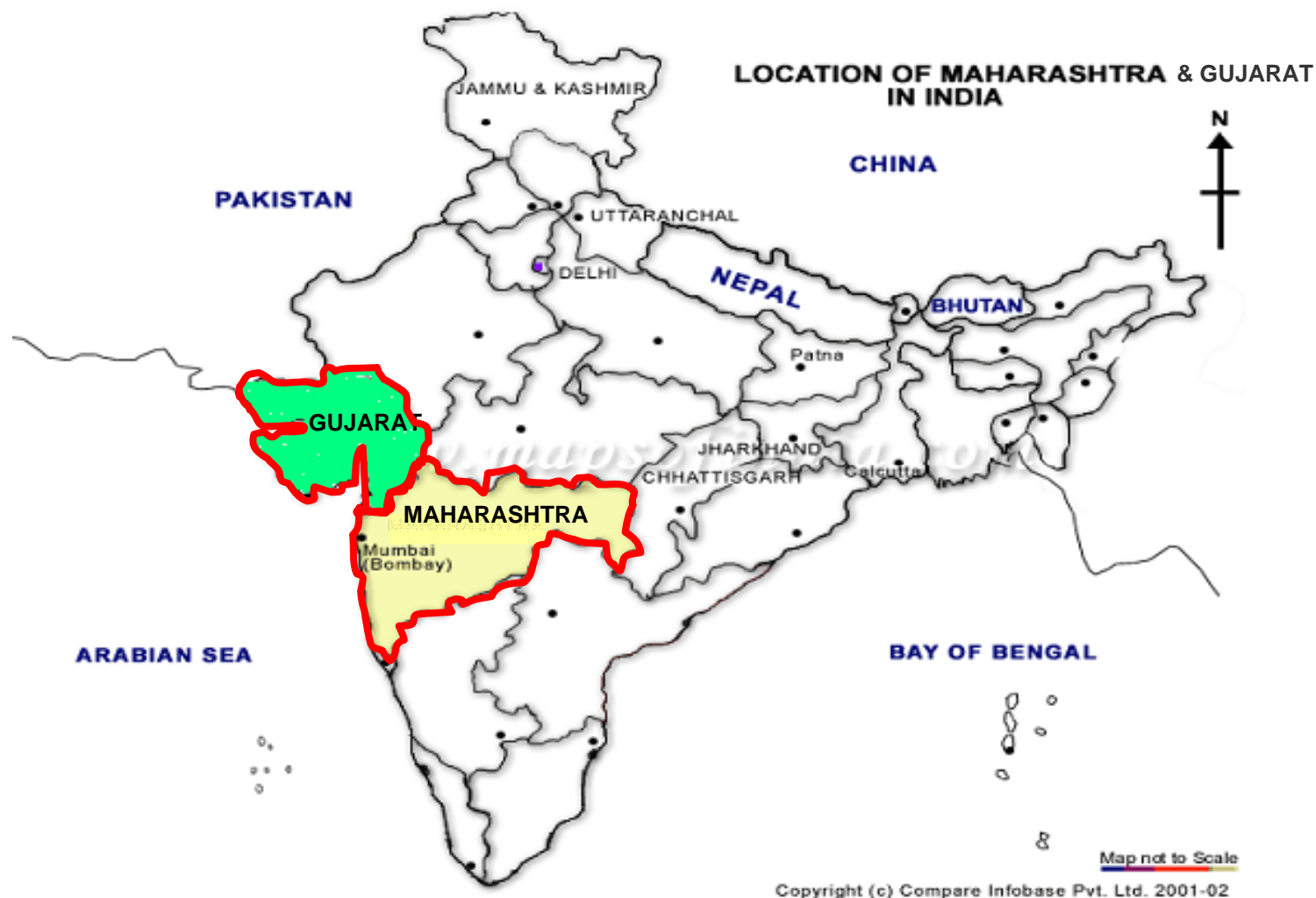

# Organic Pigments in India : Capacities (MT/y)

<u>Sector</u>	<u>Capacity</u>	<u>%</u>
Organized	ca. 49,500	60
SSI	ca. 30,500	40
<b>Total</b>	<b>ca. 80,000</b>	<b>100</b>

<u>Pigment type</u>	<u>Capacity</u>
Azos	ca. 20,000
Phthalos	ca. 56,000
HPPs	ca. 4,000
<b>Total</b>	<b>ca. 80,000</b>

- China has estimated capacity of 185,000 MT which is largely used for export business.

# Major Pigment Types manufactured in India (MT/Y)



Exactly your chemistry.

## ■ Phthalos

	<u>Blue 15</u>	<u>Green 7</u>	<u>CPC Crude</u>
– Organised	17,000	8,000	28,000
– Small Manufacturers	8,800	4,700	9,000
<b>TOTAL</b>	<b>25,800</b>	<b>12,700</b>	<b>37,000</b>

## ■ Azos

– Organized	9,000
– Small Sector Manufacturers	6,000
<b>TOTAL</b>	<b>15,000</b>

■ Pigment Violet 23 1,000

# *Phthalo Blue Producers in India: Organised Sector*



Exactly your chemistry.

- Major producers are : Asahi Songwon, Clariant, Heubach, Ishan Dyes, Lona, Mazda, Meghmani, Phthalo Colours, Sudarshan, SBS Colours, etc.
  
- Produce Phthalo Blue Crude, Blue Finished and Green [ Green 7 and Green 36] pigments
  
- Several variants (polymorphs) of blue e.g. Blue 15:0, 15:1, 15:2, 15:3 & 15:4 with different hues, fastness properties , chroma and tinting strength..
  
- Estimated production:
  - CPC Blue Crude                      28,000 MT/y
  - Phthalo Blues                        17,000 MT/y
  - Phthalo Green 7                    8,000 MT/y

# *Phthalo Blue Producers in India: Small / Medium Scale Sector*



Exactly your chemistry.

- Major producers are: A-One Chemicals, Bhabhani Pigments, Choksi Colours  
Dhanveen Pigments, Dhanalaxmi Pigments  
Mallack Industries, Narayan Organics,  
Ramdev Chemicals, Subhashri Pigments etc.
  
- Estimated production
  - CPC Blue Crude 9,000 MT/y
  - Phthalo Blues 8,800 MT/y
  - Phthalo Green 7 4,700 MT/y

# *Azo Pigment Producers in India: Organised Sector*



Exactly your chemistry.

- Major producers are:
  - Clariant
  - Heubach
  - Micro / Huber Inks
  - Pidilite
  - Sudarshan
- Estimated production 9,000 MT/y
- Product range Greenish Yellow – Yellow – Orange – Red – Bluish Red
- Chemistry Monoazo, Disazo, Disazo condensation, Beta Naphthol, BON acid and Naphthol based

## *Azo Pigment Producers in India: Small / Medium Scale Sector*

---



Exactly your chemistry.

- No. of small scale manufacturers are : ca.40
- Estimated production : 6,000 MT/y
- Top 10 manufacturers account for 70% of estimated production
- Major manufacturers in this segment : Anupam Pigments, Apex Dyes, Advaitya Dyechem, Bajaj Chemicals, Cosmos Colour, Ducol, Hercules Pigments, Kwality Chem, Prasad International etc.



## *Fig. Violet 23 Producers in India*

■ Estimated production : 1,000 MT/y

■ Major manufacturers : Alpanil  
Meghmani  
Ami  
Dipen  
Heubach  
Pidilite

# *Role Of Chemical Engineering and Technology*

## Improvements in Processes & Operations

- Pigment Manufacturing has remained essentially a **batch process** involving several **unit processes & operations**.
- Improvement in Chemical Engineering has led to **process optimization** through effective implementations of unit operations.
- Computer aided **Data Acquisition and Control Systems** as well as **instrumentation** have helped in better process control, reliability and reproducibility.
- Operations involving large **material handling** have also **improved** e.g. conveyor **belts** and **granulation** for press cakes, **belt**  and **spin flash drying**, **air jet milling**  and **pneumatic conveying** of pigment powders.
- In tune with tremendous **growth in IT**, the '**E business**' will certainly lead to higher **customer satisfaction & cost saving** on the long run.



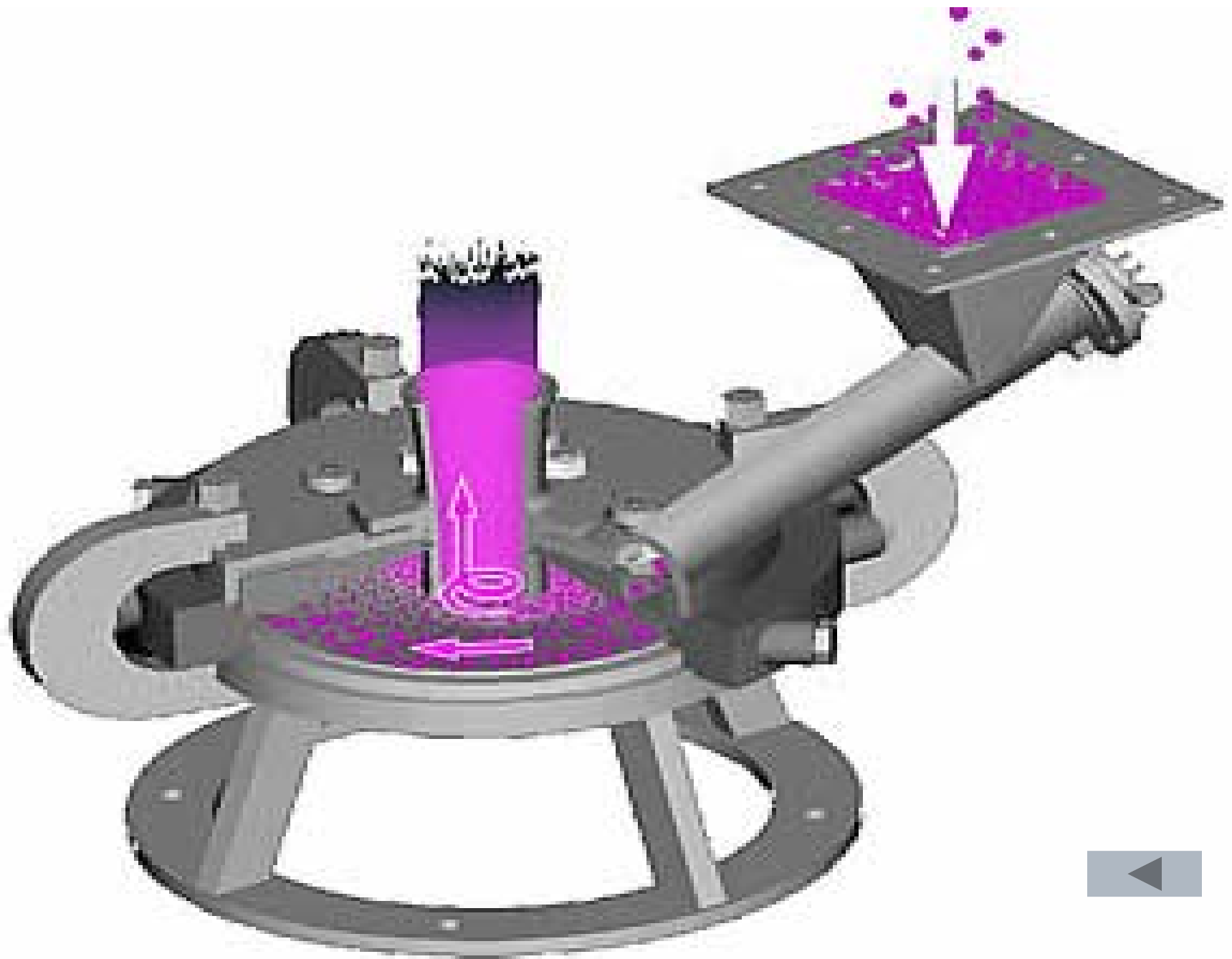

# Research & Development : Philosophy

■ Introduction of a **commercially viable new pigment molecule** is a rare occasion ! Thus, in the past 70 years, very few new classes were commercialized.

–	1940s	Phthalocyanines
–	1950s	Dioxazine violet
–	1960s	Benzimidazolones
–	1970s	Quinacridones
–	1980s	DPPs
–	1990s	-----?
–	2000s	-----?

■ It is, generally, perceived that we have a **low end, medium grade & high end** product in each hue from **yellow through orange to green** for all types of applications.

■ For Example:

Pigment Red 3  
(Naphthol Red)

Pigment Red 170  
(Naphthol AS type)

Pigment Red 254  
(DPP)

# Research & Development : Current Trends



Exactly your chemistry.

- The current trend is to **improve application properties** of existing classical pigments, rather than **researching for new molecules**. Thus, more resources are invested **Development** work rather than in **Basic Research**.
- Developmental work is mainly concerning:
  - **Solid solutions** through Mixed Coupling
  - **New crystalline modifications**
  - Changing **particle morphology**, i.e. shape, size & particle size distribution.
  - **Modifications of pigment surface** with a broad array of surfactants, additives & auxiliaries.
- **'Ready to use'** Pigment Preparations / Pigments for ease of incorporation in application systems ensuring optimum of strength in a faster & cost effective way.

# Pigment Intermediates Production in India

- Most of the important intermediates are produced in India.
- Some, which are used in large quantities, are also imported from China for price considerations e.g. MNPT, Beta Naphthol , Naphthol AS types, Acetoacetarylides etc.
- Major intermediates for basic shades of Yellow ,Orange, Red, Blue, Green & Violet are :

<u>Shade</u>	<u>Intermediates</u>
Yellow	DCB, MNPT, PCONA, Fast Red B Base, Amino-Dimethyl -Pterphthalate Acetoacetarylides, Diacetoacetarylides, etc
Orange	DCB, Pyrazolone derivatives, Beta Naphthol etc.
Red	PTMSA, CLT Acid, 2 B Acid, MNPT, MNPA, Fast Red RL Base, 2,5-Dichloroaniline, 2,4,5-Trichloroaniline, BON Acid, Beta Naphthol, Naphthol AS types etc.
Blue	Phthalic anhydride, Urea, Copper Chloride etc.
Green	CPC Blue crude, Aluminium Chloride, Chlorine, Bromine, etc.
Violet	Hydroquinone, Carbazole, etc.

# Pigment Intermediates: Manufacturers & their major products

Sr.No.	Intermediate	Manufacturers	
		Organised Sector	SSI
1	DCB	Aarti Industries	
		Hemani Industries	
2	Fast Red B base	Aarti Industries	Nandosal Chemicals
		Sajjan India Pvt.Ltd	
3	Fast Red RL base		Ratnakar Chemicals
4	PCONA	Aarti Industries	Premier Industries
5	MNPA	Aarti Industries	Thakkar Dye-Chem
			Jay Chemicals
6	P - Amino Benzamide	Aarti Industries	Daikaffil Chemicals
7	2,5-Dichloroaniline	Aarti Industries	Val Organics
			Supreet Industries
8	DMT (Dimethyl Pterpathalate)	Nanavati Chemicals	
9	2,4,5 Trichloroaniline	Yashasvi Rasayan	Hema Dye Chem
10	Beta Naphthol	Multi Organics	
		Bodal	

... (Contd)

# Pigment Intermediates: Manufacturers & their major products



Exactly your chemistry.

Sr.No.	Intermediate	Manufacturers	
		Organised Sector	SSI
11	Phthalic Anhydride	Thirumalai Chemicals	
12	CPC Blude Crude etc	Phthalo Colours	
		Loana Industries	
		Asahi Songwon	
		Bhabani Chemicals	
		Melida (China)	
		Jeco (China)	
13	Aluminium Chloride	Arkema Chemicals	
		Kanoria Chemicals	
14	Hydroquinone	Mitsui (Japan)	
		Eastman (USA)	
15	Urea	RCF	
16	MNPT		Thakkar Dye-Chem
			Jay Chemicals
17	Naphthol AS types		Daikaffil Chemicals
18	CLT Acid (2,5,4-)		Kangaroo Industries
			Mohan Polyfab
19	Carbazole		Nova International

# *Toxicological & Ecological Issues : A Vital Consideration*

---

- Control of Trace Impurities:
  - Heavy metals
  - Aromatic amines (MAK III class)
  - Polychlorobiphenyls
  - Dioxines etc.
  
- Restrictions from Western countries:
  - Can adversely affect exports esp. to western Europe & USA
  
- Increasing awareness in other countries:
  - Australia, Canada, China, Korea, New Zealand, Philippines also have their 'chemical inventories' in place which must be satisfied by the exporters of colourants.

**In future, both legislative and social forces will control tox and ecotox issues.**

# *Pigment Industry : Road Ahead !*



Exactly your chemistry.

- Indian Pigment and Intermediates Industry is facing challenges on several fronts : escalating **costs**, stricter **environmental** and **product safety** regulations and competition from **low cost countries**, e.g. China.
- However , these very **challenges** could be converted into **opportunities** through improved products and optimized processes.
- **High performance** pigments of today will become conventional **standards** of tomorrow
- Pigment business is about **constant change**; in supply of better **products** and **service** to customers
- Future challenges to Indian Pigment Industry can be briefly designated as 3 essential 'E's
  - Effectiveness
  - Economy
  - Ecology
- Hopefully, the Indian industry meets these challenges and becomes a **leader of the global pigment industry!**

*Have a nice day !!*

